

MODEL NUMBER	HHI1.5-18-145T		
HORSEPOWER	1.5		
RPM / POLES	1800 / 4		
VOLTAGE / PHASE	230 / 460 V / 3		
FRAME	145T		
ENCLOSURE / DEGREE OF PROTECTION	TEFC / IP55		
FREQUENCY	60 HZ		
FULL LOAD SPEED	1735 RPM		
SERVICE FACTOR	1.15 SF at 40° C / 1.0 SF at 65° C		
INSULATION CLASS	F Class N Varnish		
FULL LOAD AMPS; 230 / 460	4.4 / 2.2 A Usable On 208 V At 4.9 A		
LOCKED ROTOR CURRENT (% Full Load)	900 / 900 %		
NEMA CODE LETTER	M		
EFFICIENCY / POWER FACTOR	<u>LOAD</u>	<u>EFF.</u>	<u>P.F.</u>
	100 %	86.5 %	72.0 %
	75 %	86.7 %	62.0 %
	50 %	80.5 %	48.0 %
DUTY CYCLE	S1 / Continuous		
TORQUE	<u>FULL LOAD</u>	<u>LRT</u>	<u>BDT</u>
	4.5 lb.ft.	260 %	290 %
NEMA DESIGN	B		
MOMENT OF INERTIA	<u>LOAD (Max.)</u>	<u>MOTOR</u>	
	24.278 lb.ft. ²	0.076 lb.ft. ²	
SOUND PRESSURE LEVEL (No Load 1 M From Motor)	63 dB(A)		
NUMBER OF STARTS (Hot / Cold)	2 Hot / 3 Cold		
MAX. AMBIENT TEMPERATURE	40° C at 1.15 SF / 65° C at 1.0 SF		
MAX. ELEVATION	3300 Ft. Above Sea Level		
TEMPERATURE RISE (At Full Load)	80° C		
DRIVE-END BEARING	6205ZZC3		
OPPOSITE DRIVE-END BEARING	6204ZZC3		
GREASE TYPE	Mobil Polyrex EM		
MOUNTING	F1 (F2 Suitable), W6, W8, B3, V5, V6		
ROTATION	Bi-Directional		
APPROXIMATE WEIGHT	55 lbs.		
AREA CLASSIFICATION	Class I, Division 2, Groups A, B, C, D		
INVERTER RATING	10:1 CT / 20:1 VT		
SPECIFICATION - In Accordance With	NEMA, CSA		



CC 038A





TEFC

THREE PHASE INDUCTION MOTOR

TYPE

LP,JP

CAST IRON FRAME

FRAME SIZE

OUTPUT(HP)

POLES

Hz

TIME RATING

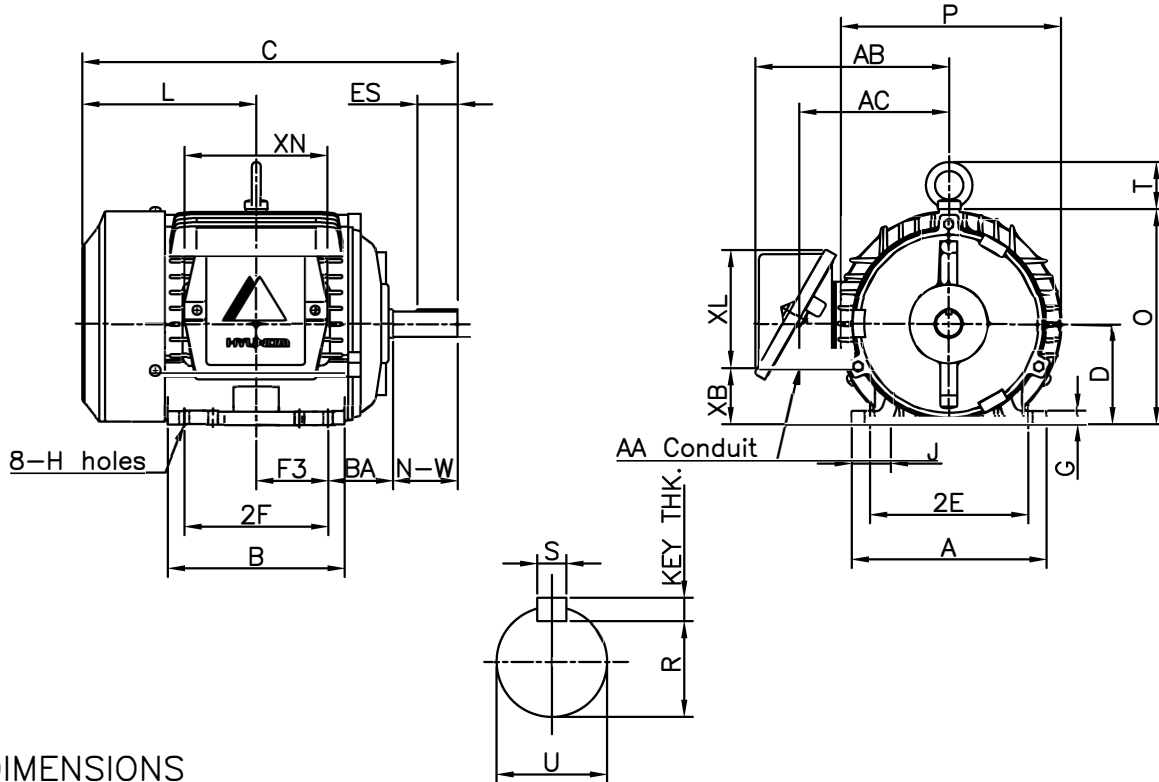

DIMENSIONS

MOUNTING									CONDUIT BOX						APPROX. WGT.(LB)
A	B	2E	2F	-	F3	G	J	H	AA	AB	AC	XB	XL	XN	
6.78	6.15	5.50	5.00	-	2.50	0.47	1.36	0.34	0.75	6.73	5.21	1.95	4.10	4.96	55

OVERALL						SHAFT						KEY THK.	BEARING	
BA	C	D	L	O	P	T	U	N-W	KEYWAY				DRIVE END	OPP. DRIVE END
									R	ES	S			
2.25	13.05	3.50	6.05	7.46	7.64	1.63	0.875	2.25	0.771	1.41	0.188	0.188	6205ZZC3	6204ZZC3

NOTE

- 1.Dimension "D" tolerance : +0.00inch - 0.03inch
- 2.Dimension "U" tolerance : +0.000inch - 0.0005inch
- 3.Dimension "R" tolerance : +0.000inch - 0.015inch

APPD BY	J.H.KIM	UNIT	INCH	SUBJECT	NEMA 145T	CAD PROJ \ FILE
CHKD BY	N.D.LEE	SCALE	1/8			SCALE-NEMA\A1102AA
CHKD BY	K.S.LEE	PROJEC'N	3rd Angle	TITLE OUTLINE		
DSND BY	S.W.SEO	DATE	2010.12.20			

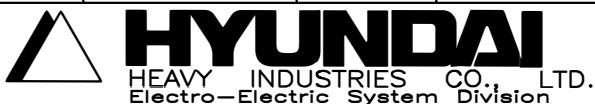

REF. NO	350A1102AA	Sheet No.	of
DWG NO	350A1102AA	Revision No.	0

Type	:	PLP
Full Load Torque	:	4.5 lb.ft
Motor moment of Inertia (J)	:	0.076 lb.ft ²
Load moment of Inertia (J)	:	24.278 lb.ft ²

1.1 kW	1.5 HP	60 Hz	
4 P	Rated Speed	: 1735 RPM	
Rated Voltage	575V	460V	230V
Full Load Current	1.8A	2.2A	4.4A

SPEED VS TORQUE & CURRENT CURVE

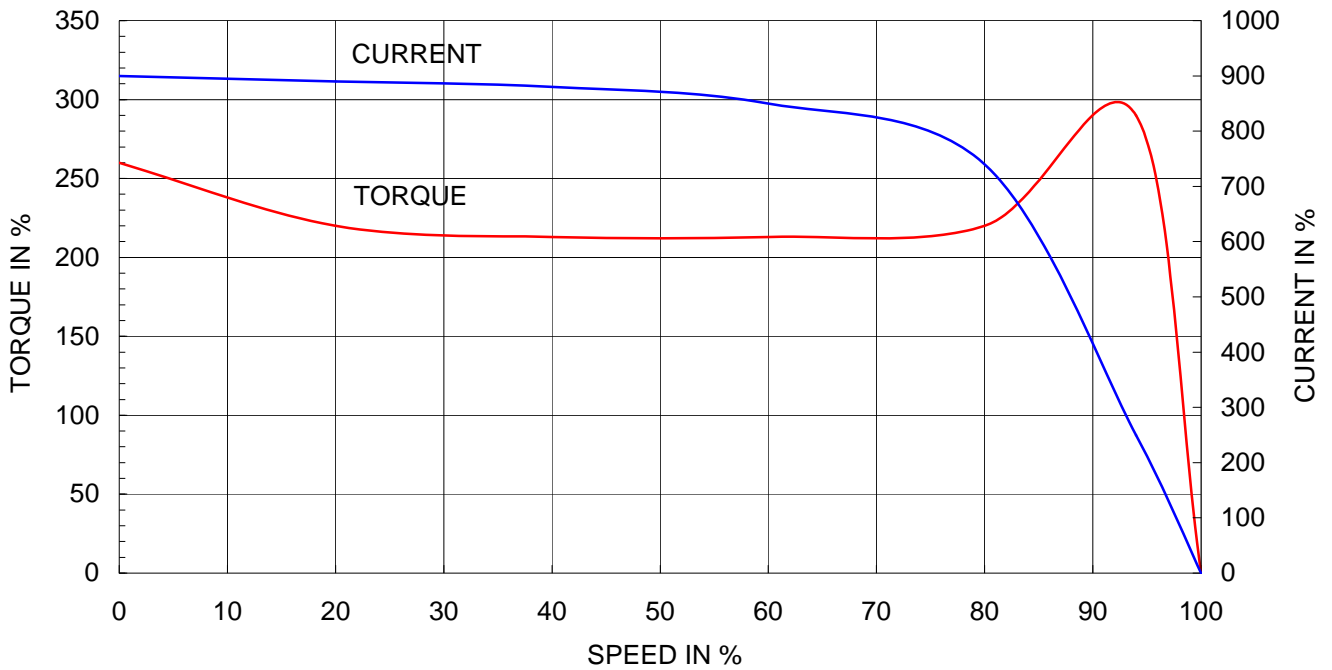

OUTPUT VS EFF., P.F & CURRENT CURVE

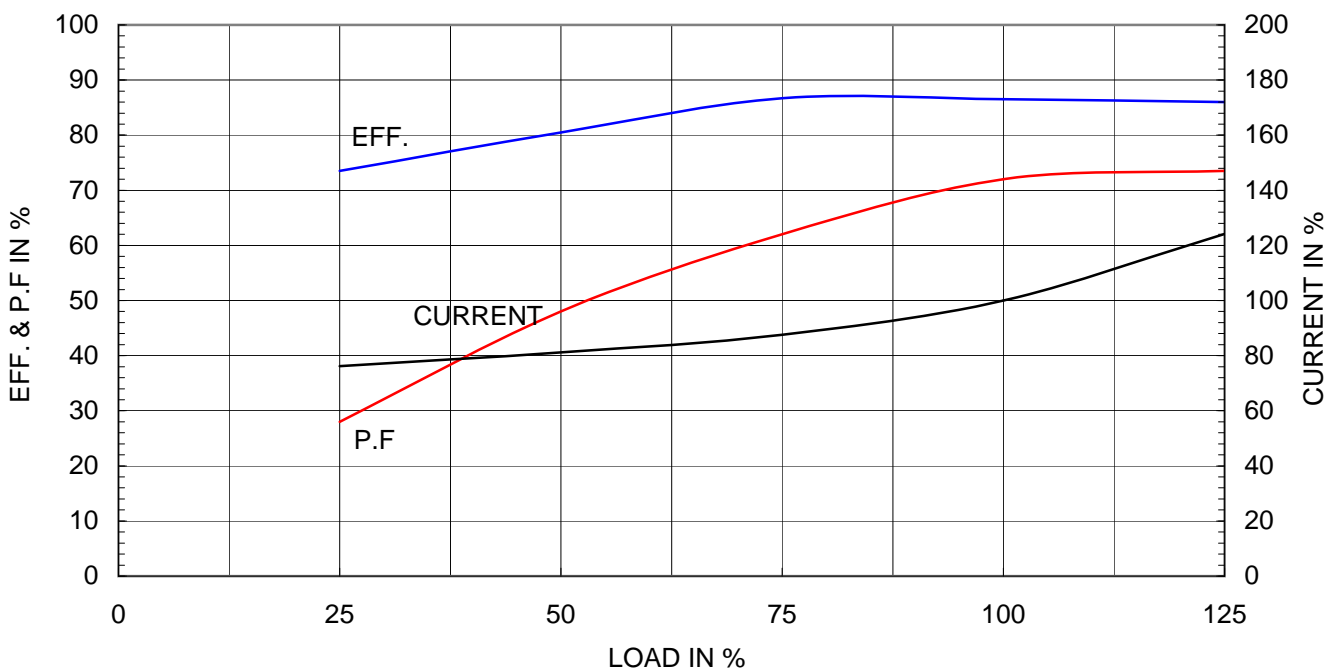



THERMAL LIMIT & TIME CURRENT CURVE

CURVE NO.

T-PLP1.5-18-145T

Type :	PLP1.5-18-145T	
FULL LOAD TORQUE :	4.5	lb.ft
J OF LOAD :	-	lb.ft ²
J OF MOTOR :	0.1	lb.ft ²

1.5	HP	4	P	60	Hz
RATED SPEED :			1735 rpm		
VOLTAGE		460 V	575 V		
RATED CURRENT		2.2A	1.8A		

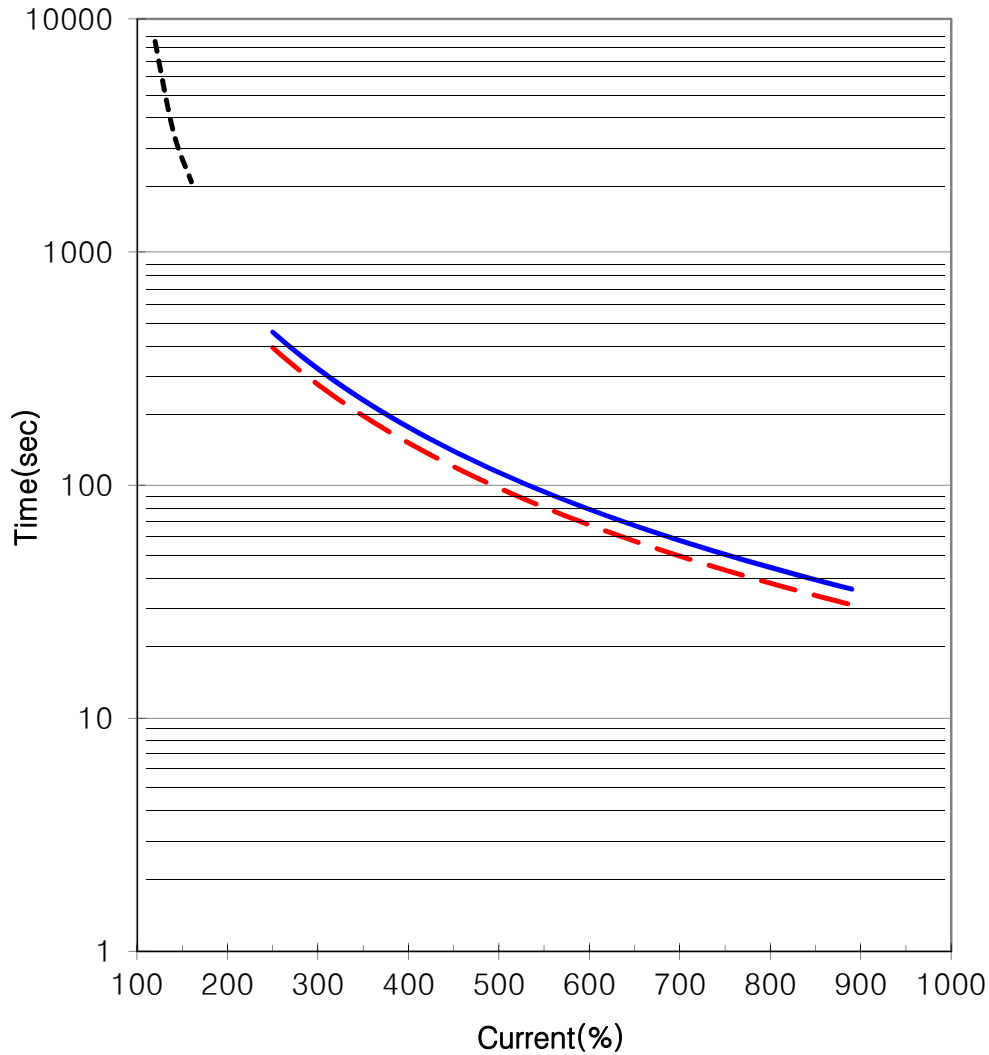

— THERMAL LIMIT CURVE AT COLD CONDITION
- - THERMAL LIMIT CURVE AT HOT CONDITION

STARTING TIME	SAFE STALL TIME
- at rated voltage starting	30 sec. at Hot condition
- at 80% of rated voltage starting	35 sec. at Cold condition

THIS DRAWING IS PROPRIETARY TO HHI. NO PART OF THIS DRAWING MAY BE REPRODUCED WITHOUT THE PERMISSION OF HHI.

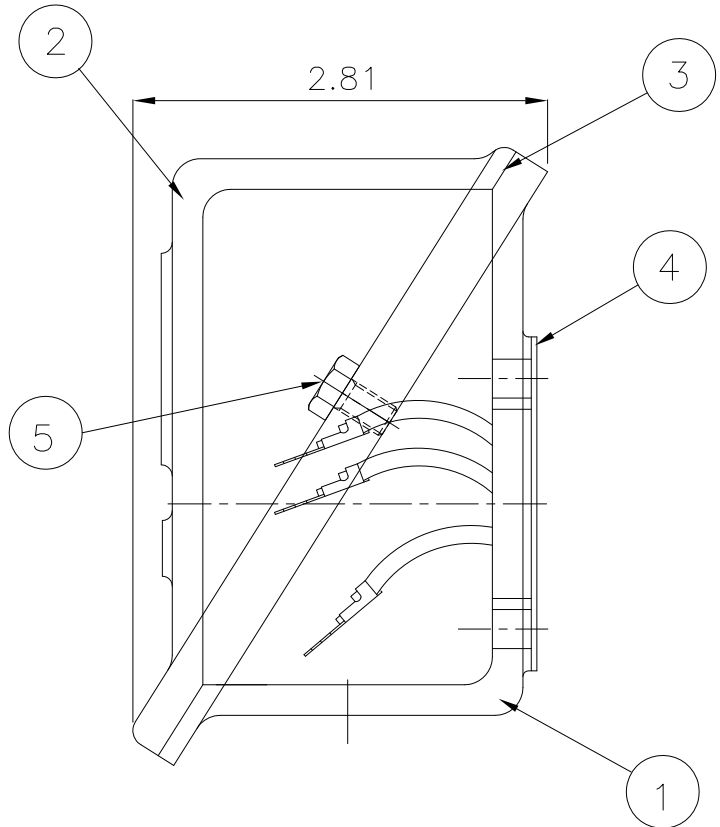
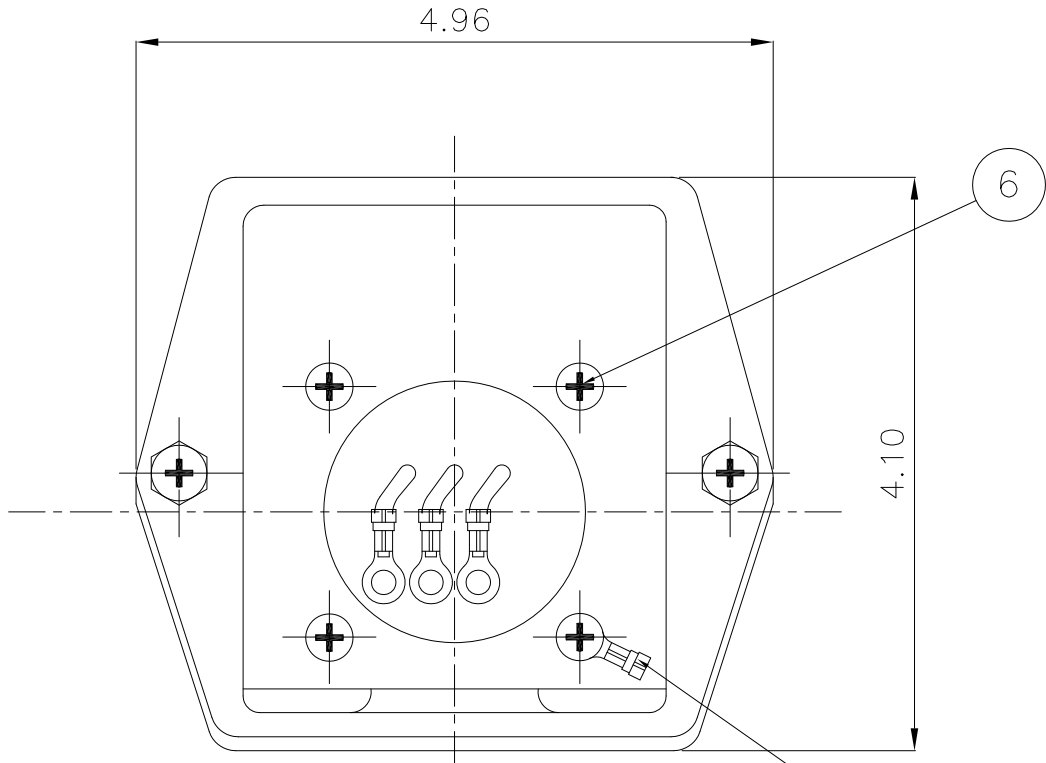

PT	DESCRIPTION	MATERIAL	DIMENSION	Q'TY
1	CONDUIT BOX	FC15	--	1
2	CONDUIT BOX COVER	FC15	--	1
3	O-RING / COVER	NBR	--	1
4	BOX GASKET	NBR	--	1
5	COVER+BOX HEX BOLT	S45C	M5 X L15	4
6	BOX+FRAME HEX BOLT	S45C	M5 X L15	4
7	GROUND TERMINAL LUG	CU	M5X5.5mmSQ	1

Q'TY	DESCRIPTION	MATERIAL	DIMENSION	WEIGHT	PART NO.	REMARK	NO.
APPD BY	B.M.YOO	UNIT	INCH	SUBJECT		NEMA 140	
CHKD BY	S.W.SEO	SCALE	1/0.46	TITLE		3 LEADS	
CHKD BY	J.S.JEONG	PROJEC'N	3rd Angle	CONDUIT BOX ASSEMBLY			
DSND BY	C.S.KO	DATE	2008.01.18	REF. NO	227B1535AA2	Sheet No.	of
				DWG NO	227B1535AA2	Revision No.	1

REV	DATE	CONTENTS	REVD BY	CHKD BY	CHKD BY	APPD BY
1						