

MODEL NUMBER	HHI40-18-324T-F2		
HORSEPOWER	40		
RPM / POLES	1800 / 4		
VOLTAGE / PHASE	230 / 460 V / 3		
FRAME	324T		
ENCLOSURE / DEGREE OF PROTECTION	TEFC / IP55		
FREQUENCY	60 HZ		
FULL LOAD SPEED	1780 RPM		
SERVICE FACTOR	1.15 SF at 40° C / 1.0 SF at 65° C		
INSULATION CLASS	F Class N Varnish		
FULL LOAD AMPS; 230 / 460	97.6 / 48.8 A Usable On 208 V At 108 A		
LOCKED ROTOR CURRENT (% Full Load)	700 / 700 %		
NEMA CODE LETTER	H		
EFFICIENCY / POWER FACTOR	<u>LOAD</u>	<u>EFF.</u>	<u>P.F.</u>
	100 %	94.1 %	82.0 %
	75 %	94.1 %	79.0 %
	50 %	93.1 %	73.5 %
DUTY CYCLE	S1 / Continuous		
TORQUE	<u>FULL LOAD</u>	<u>LRT</u>	<u>BDT</u>
	118.7 lb.ft.	160 %	220 %
NEMA DESIGN	B		
MOMENT OF INERTIA	<u>LOAD (Max.)</u>	<u>MOTOR</u>	
	409.301 lb.ft. ²	7.121 lb.ft. ²	
SOUND PRESSURE LEVEL (No Load 1 M From Motor)	75 dB(A)		
NUMBER OF STARTS (Hot / Cold)	2 Hot / 3 Cold		
MAX. AMBIENT TEMPERATURE	40° C at 1.15 SF / 65° C at 1.0 SF		
MAX. ELEVATION	3300 Ft. Above Sea Level		
TEMPERATURE RISE (At Full Load)	80° C		
DRIVE-END BEARING	6313ZC3		
OPPOSITE DRIVE-END BEARING	6211ZC3		
GREASE TYPE	Mobil Polyrex EM		
MOUNTING	F2 (F1 Suitable), W6, W8, B3, V5, V6		
ROTATION	Bi-Directional		
APPROXIMATE WEIGHT	626 lbs.		
AREA CLASSIFICATION	Class I, Division 2, Groups A, B, C, D		
INVERTER RATING	10:1 CT / 20:1 VT - Meets NEMA MG1 Part 31		
SPECIFICATION - In Accordance With	NEMA, CSA		



CC 038A





TEFC

THREE PHASE INDUCTION MOTOR

TYPE

LP, JP

CAST IRON FRAME

FRAME SIZE

OUTPUT(HP)

POLES

Hz

TIME RATING

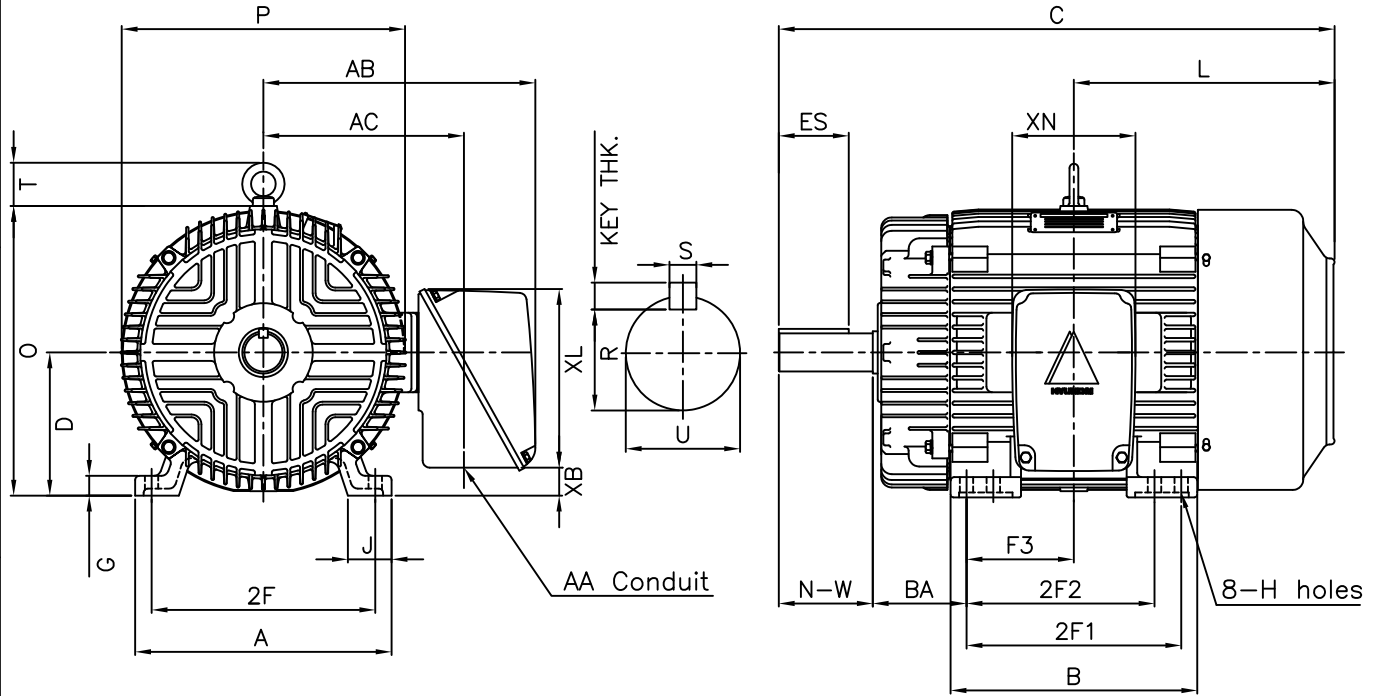

DIMENSIONS

M O U N T I N G									C O N D U I T B O X						APPROX. WGT.(LB)	
A	B	2E	2F1 ⁵⁾	2F2 ⁴⁾	F3	G	J	H	AA	AB	AC	XB	XL	XN	324T	326T
14.33	13.78	12.50	12.00	10.50	6.00	1.11	2.36	0.66	2.00	15.20	11.21	1.57	10.16	7.01	550	560

O V E R A L L								S H A F T			KEY THK.	B E A R I N G		
BA	C	D	L	O	P	T	U	N-W	KEYWAY			DRIVE END	OPP. DRIVE END	
									R	ES	S			
5.25	31.07	8.00	14.57	16.19	15.84	2.41	2.125	5.25	1.845	3.91	0.500	0.500	6313ZC3	6211ZC3

NOTE

- 1.Dimension "D" tolerance : +0.00inch - 0.03inch
- 2.Dimension "U" tolerance : +0.000inch - 0.001inch
- 3.Dimension "R" tolerance : +0.000inch - 0.015inch
- 4.Location of holes for 324T frame
- 5.Location of holes for 326T frame

APPD BY	KIM.Y.S	UNIT	INCH	SUBJECT	NEMA 324T/326T	CAD PROJ \ FILE		
CHKD BY	KO.S.H	SCALE	1/12			XSMOUTN\A1112AA		
CHKD BY		PROJEC'N	3rd Angle	TITLE				OUTLINE
DSND BY	LEE KWANG SOO	DATE	2004.04.02					

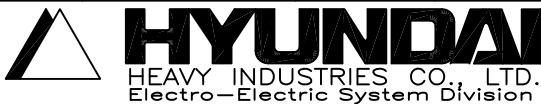

REF. NO	A1112AA	Sheet No.	of
DWG NO	350A1112AA	Revision No.	0

Type	: PLP
Full Load Torque	: 118.7 lb.ft
Motor moment of Inertia (J)	: 7.121 lb.ft ²
Load moment of Inertia (J)	: 409.301 lb.ft ²

30 kW	40 HP	60 Hz	
4 P	Rated Speed	: 1780 RPM	
Rated Voltage	575V	460V	230V
Full Load Current	39.0A	48.8A	97.6A

SPEED VS TORQUE & CURRENT CURVE

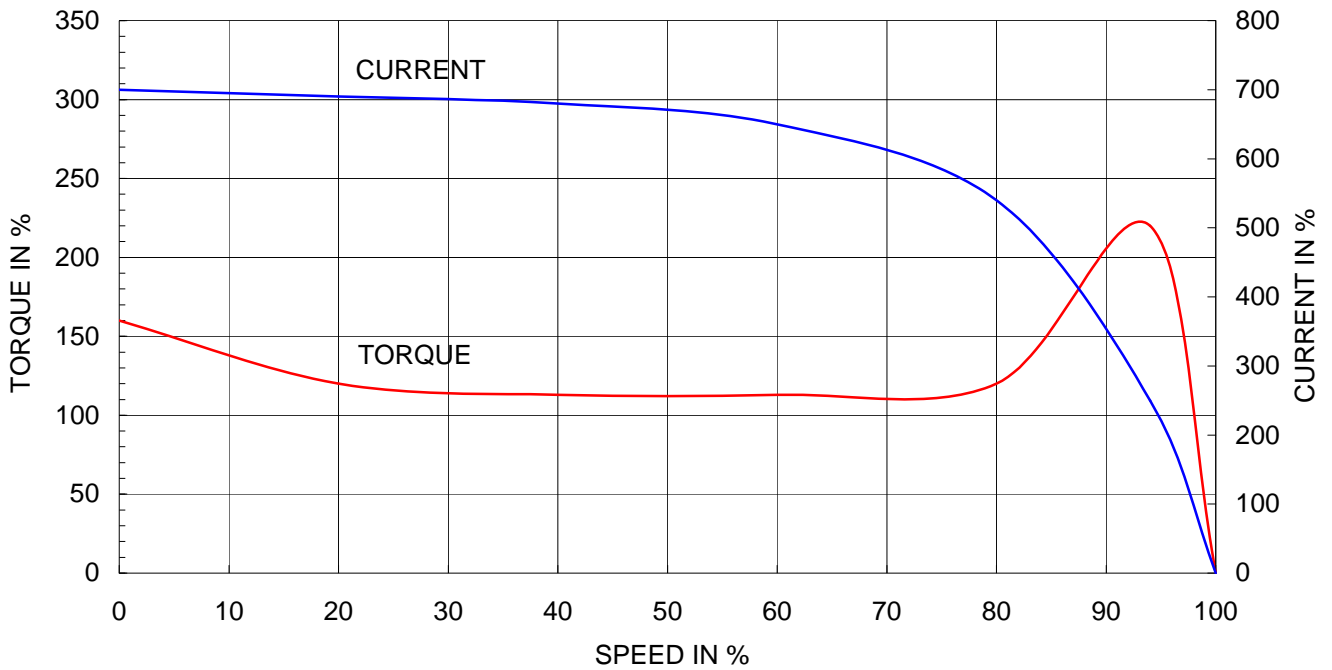

OUTPUT VS EFF., P.F & CURRENT CURVE

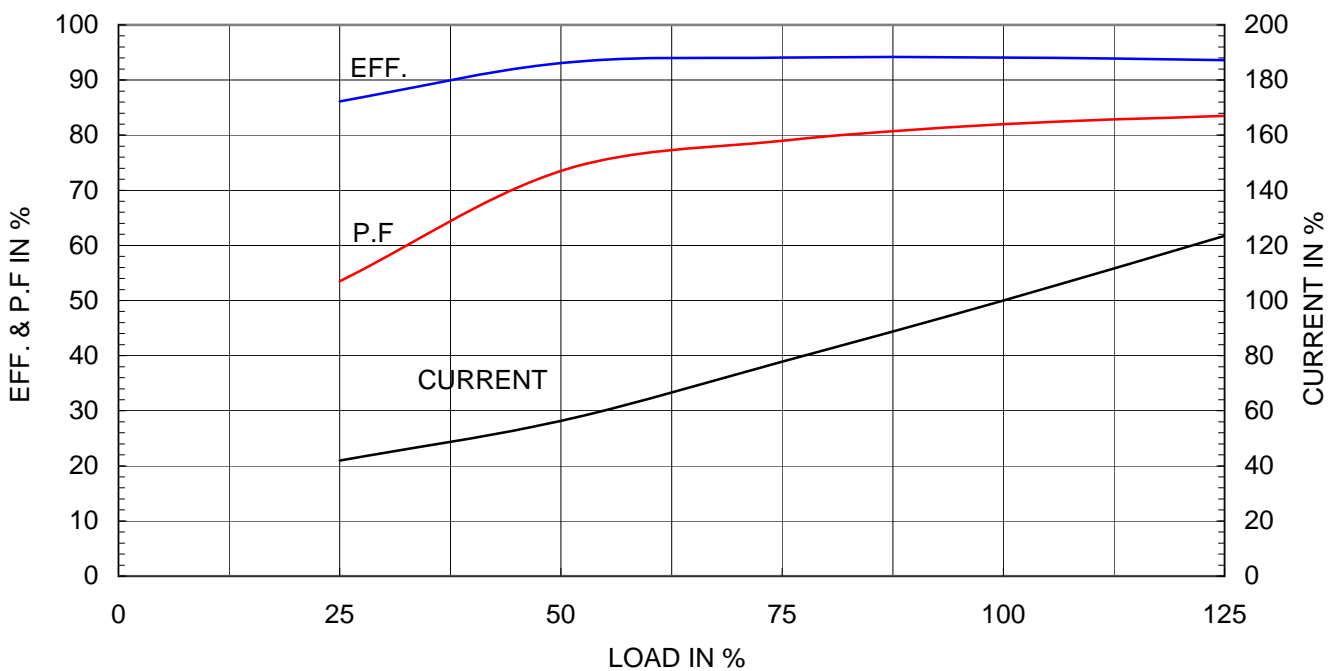



THERMAL LIMIT & TIME CURRENT CURVE

CURVE NO.

T-PLP40-18-324T-F2

Type :	PLP40-18-324T	40	HP	4	P	60	Hz
FULL LOAD TORQUE :	118.7	lb.ft	RATED SPEED :		1780 rpm		
J OF LOAD :	-	lb.ft ²	VOLTAGE		460 V	575 V	
J OF MOTOR :	7.1	lb.ft ²	RATED CURRENT		48.8A	39.0A	

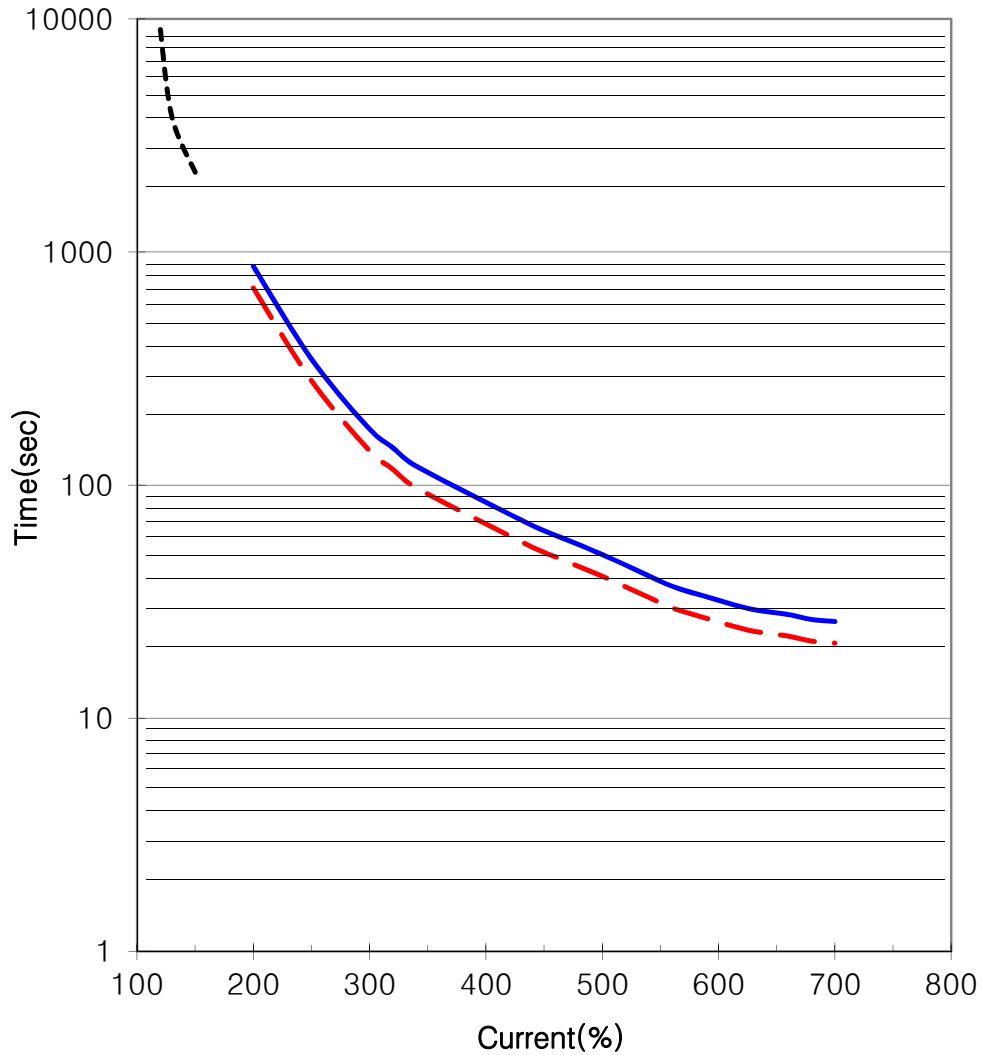

— THERMAL LIMIT CURVE AT COLD CONDITION
- - THERMAL LIMIT CURVE AT HOT CONDITION

STARTING TIME	SAFE STALL TIME
- at rated voltage starting	21 sec. at Hot condition
- at 80% of rated voltage starting	26 sec. at Cold condition

THIS DRAWING IS PROPRIETARY TO HHI. NO PART OF THIS DRAWING MAYBE REPRODUCED WITHOUT THE PERMISSION OF HHI.

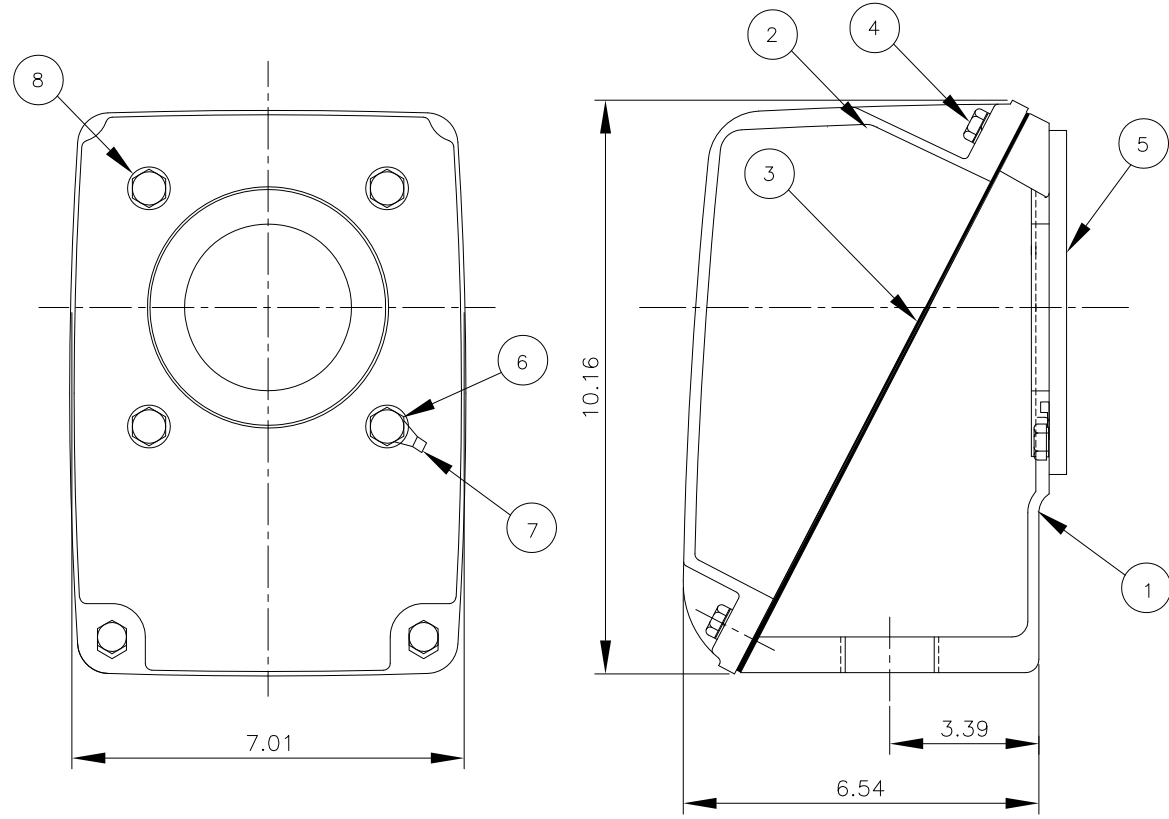

PT	DESCRIPTION	MATERIAL	DIMENSION	Q,TY
1	CONDUIT BOX	FC20		1
2	C/B COVER	FC20		1
3	GASKET(COVER)	N.B.R	T2X170X210	1
4	SCREW(COVER)	S45C	M8XL20	4
5	GASKET(C/B)	N.B.R		1
6	SCREW(C/B)	S45C	M8XL20	4
7	TERMINAL GROUND	CU	T1.6	1
8	WASHER	S45C	M8 X L10	4

▽	50S
▽▽	12.5S
▽▽▽	3.2S
▽▽▽▽	0.4S

REV	DATE	CONTENTS	REVD BY	CHKD BY	CHKD BY	APPD BY
1						

일반가공공차		일반재관공차	
1-4	±0.1	6-30	±0.5
4-18	±0.2	30-120	±0.8
18-63	±0.3	120-315	±1.2
63-250	±0.5	315-1000	±2.0
250-	±0.8	1000-	±3.0

Q'TY	DESCRIPTION	MATERIAL	DIMENSION	WEIGHT	PART NO.	REMARK	NO.
APPD BY	KANG KYEONG JUNG	UNIT	INCH	SUBJECT	NEMA 320		DWG SIZE
CHKD BY	LEE NOH DUK	SCALE	1/2	TITLE			A3 (1:30)
CHKD BY	KIM IN KYU	PROJEC'N	3각법(3rd Angle)	Main Terminal Box Assembly			
DSND BY	KIM EUN SEONG	DATE	2011-08-30	REF. NO	227B8003CB5	Sheet No.	of
				DWG NO	3M-145864	Revision No.	0